

# Motor M62

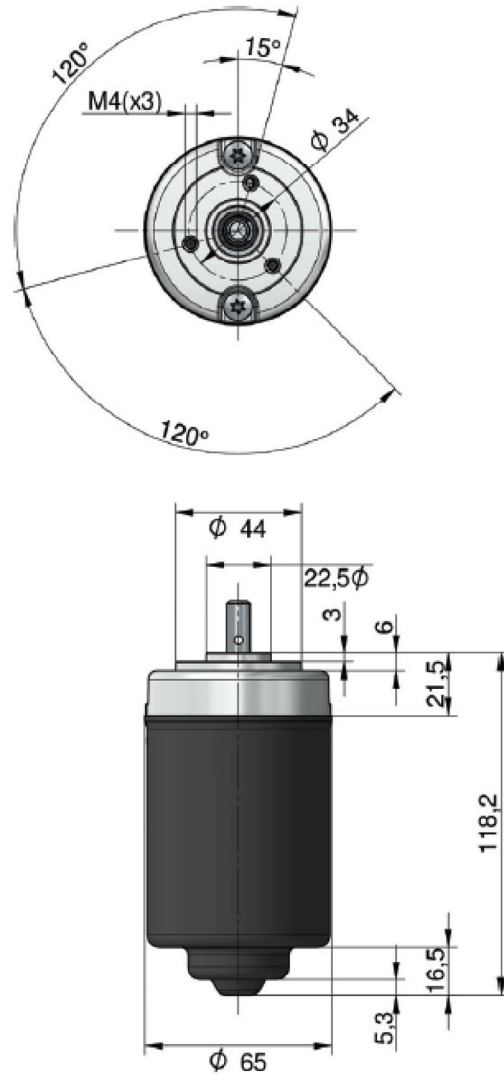

## TECHNICAL DATA

DESCRIPTION	VALUE
Supply Voltage (VDC)	12, 24, 36, 48
No Load speed (RPM)	1200-7000
Max Output Power (W)	< 100
Starting Torque (Nm)	< 2
Duty Type	S1, S2, S3
Weight (Kg)	< 0,9
Accessories	<ul style="list-style-type: none"><li>• Standard EMC filter</li><li>• Single or dual channel Hall sensor with 1, 2, 4, 12 pulses/revolution</li></ul>
Customizations	<ul style="list-style-type: none"><li>• EMC filter</li><li>• Thermal protection</li><li>• Output shaft</li><li>• Connector and wiring</li></ul>



DOWNLOAD  
MOTOR M62  
TECHNICAL SKETCH